

PSENmag

PSEN 1.1p-25



Unit features

- ▶ The actuator **PSEN 1,1-20** belongs to the safety switch
- ▶ 2 reed contacts (N/O)
- ▶ Assured operating distance: **8 mm**
- ▶ Assured release distance: **26 mm**
- ▶ Square design
- ▶ Works magnetically
- ▶ Switching voltage 24 VDC

Function description

If the actuator is within the response range, the magnets switch the reed contacts on the safety switch. If the actuator is outside the response range (safety gate open), the reed contacts on the safety switch will switch.

Unit description

The safety switch meets the requirements of EN 60204-1 and IEC 60204-1.

The safety switch is approved for use in potentially explosive atmospheres in accordance with EN 50021, Ex area Category 3, Zone 2 (gas) and 22 (dust), (II 3GD EEx nC IIC T6).

The safety switch only complies with EN 60947-5-3 in conjunction with the PSEN ix1 interface, the actuator **PSEN 1,1-20** and its approved evaluation devices. The safety switch should only be connected to the evaluation devices listed under "Connections".

Magnetic safety switches for monitoring the position of movable guards in accordance with EN 60947-5-3

Approvals

PSEN 1.1p-25	
	◆
	◆

Block diagram

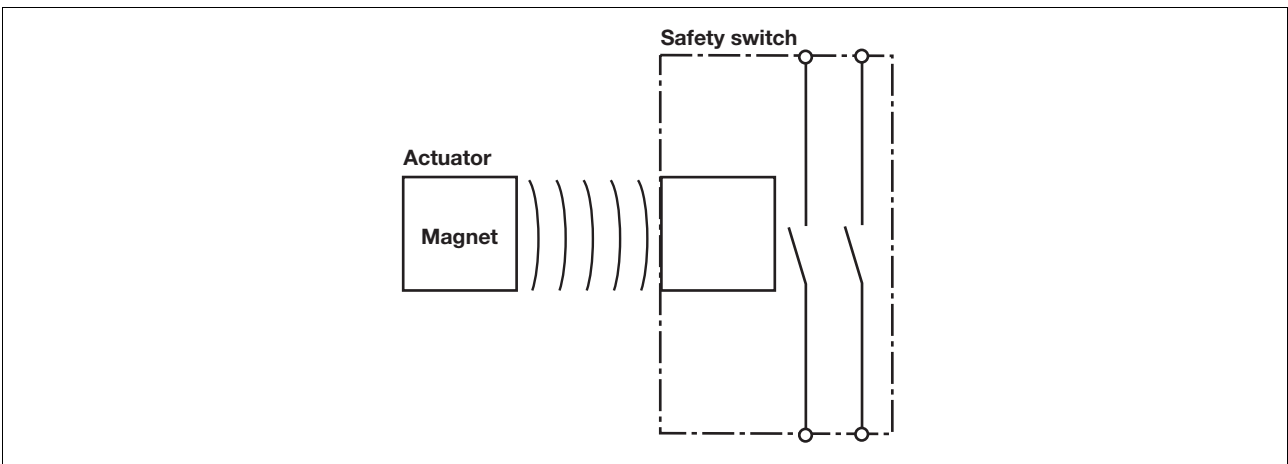

PSENmag

PSEN 1.1p-25

Operating distances

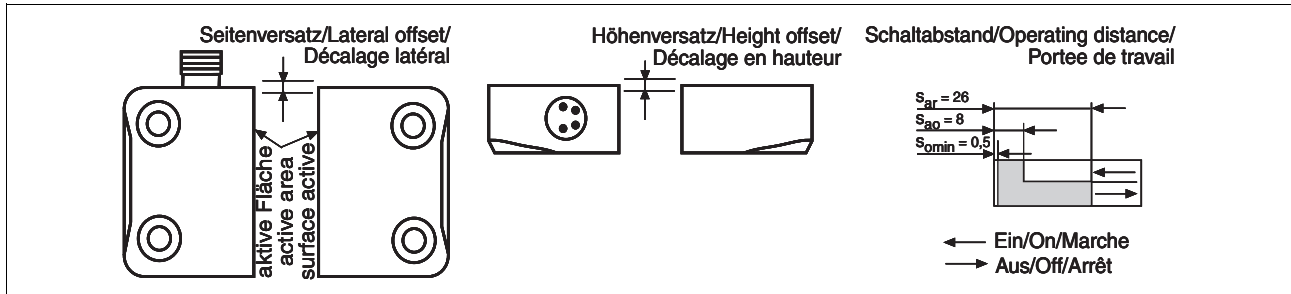

Lateral and vertical offset

- Assured operating distance S_{ao} in mm

		Höhenversatz/Height offset/ Décalage en hauteur				
		1,0	2,0	3,0	4,0	5,0
Seitenversatz/Lateral offset/Décalage latéral	1,0	7,5	7,5	7,0	7,0	5,5
	2,0	7,5	7,0	7,0	6,5	5,5
	3,0	7,0	7,0	7,0	6,0	5,5
	4,0	6,5	6,5	6,0	5,5	5,0
	5,0	6,0	6,0	6,0	5,0	4,5

- Assured release distance S_{ar} :
Max. 26 mm with all vertical and lateral offsets

The stated values are valid at a temperature of 20 °C.

Wiring

Please note:

- Information given in the "Technical details" must be followed.

- Calculation of the max. cable runs l_{max} in the input circuit:

$$l_{max} = \frac{R_{lmax}}{R_l / km}$$

R_{lmax} = max. overall cable resistance (see Technical details)

R_l / km = cable resistance/km

- When using evaluation devices with delay-on de-energisation contacts, please note:
 - Delay time ≤ 30 s: Delay-on de-energisation contacts satisfy the requirements of category 3 in accordance with EN 954-1 and the requirements of a PDF with single-fault tolerance (PDF-S).
 - Delay time ≥ 30 s: Delay-on de-energisation contacts satisfy the requirements of Category 1 in accordance with EN 954-1 and the requirements of a PDF with designed reliability (PDF-D).

- In the following commissioning cases, check the function that detects shorts across contacts:

- On evaluation devices with DC supply voltage: Overall cable resistance ≥ 15 Ohms per channel
- On evaluation devices with AC supply voltage: Overall cable resistance ≥ 25 Ohms per channel
- For details of how to perform the test for shorts across the contacts, please refer to the operating manual for the relevant evaluation device.

Connections

NOTICE

The colour marking for the connection lead only applies for the cable that Pilz supplies as an accessory. The safety switch is shown in an unoperated condition.

Belegung des 4-pol. M8-Stiftsteckers/Assignment of the 4-pin M8 male connector/Repérage du connecteur mâle M8 à 4 pôles

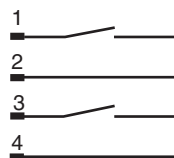

PSENmag

PSEN 1.1p-25

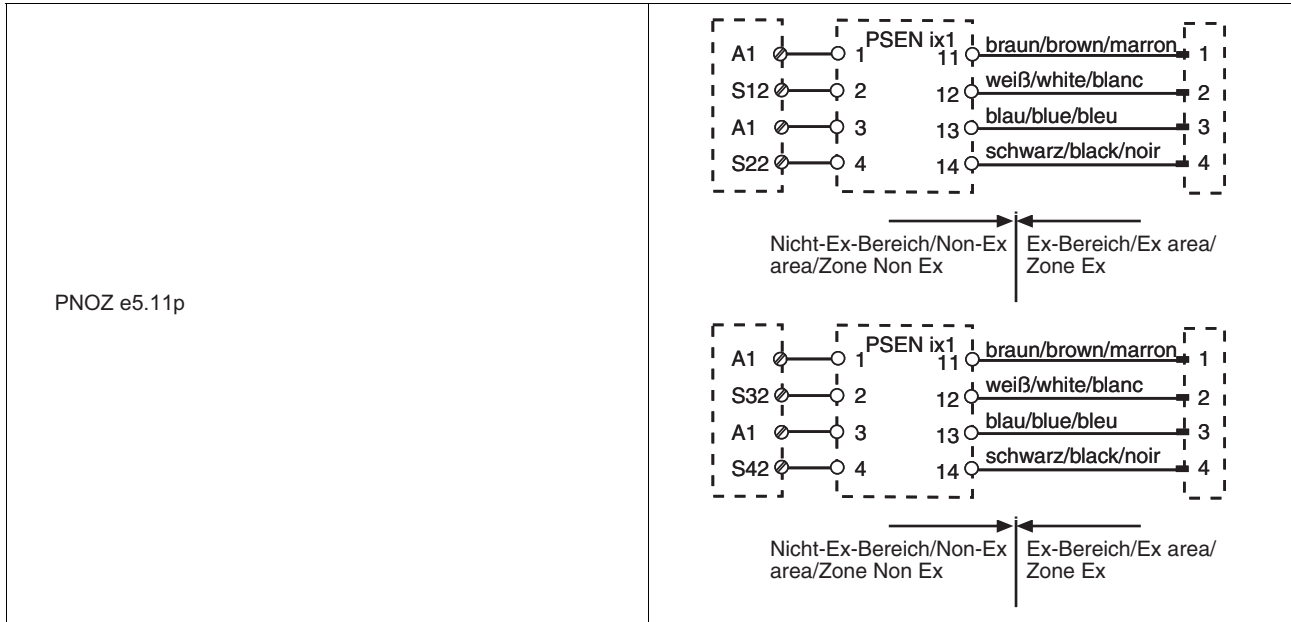

► Connection to PNOZmulti

2.2

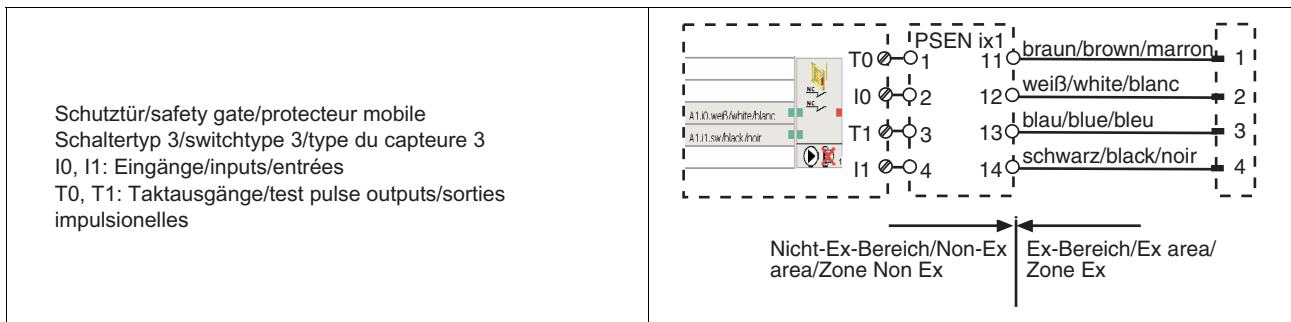

► Connection to PSS with and without SafetyBUS p

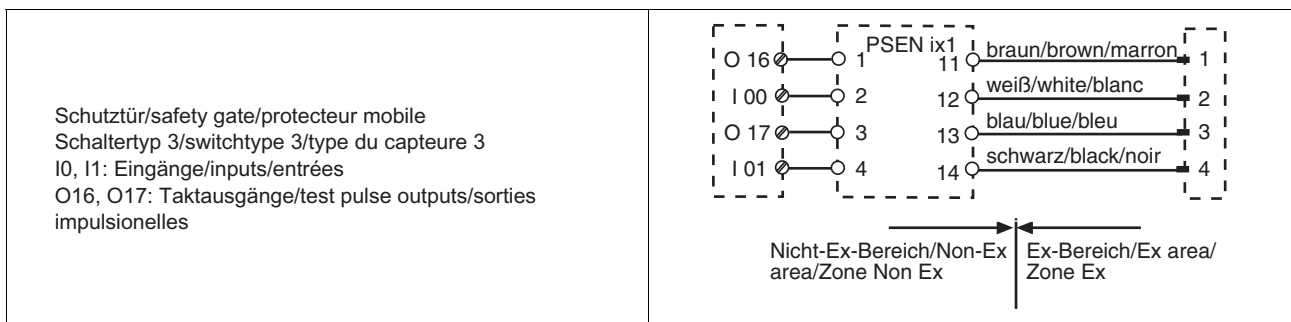

PSENmag PSEN 1.1p-25

Installation

- ▶ The unit can be installed in any position. However, safety switches and actuators must be positioned opposite each other in parallel:
- ▶ If possible, do not install the safety switch and actuator on to ferromagnetic material. Changes to the operating distances are to be expected. In this case, use the spacer available under order number 534 310.
- ▶ Safety switches and actuators should only be secured using M4 screws with a flat head (e.g. M4 cheese-head or pan head screws). Torque setting max. 1 Nm. Use screws made of non-magnetic material (e.g. Messing).
- ▶ The distance between two systems comprising safety switch and actuator must be at least 25 mm.
- ▶ Safety switch and actuator
 - Keep away from iron swarf
 - Do not expose to strong magnetic fields
 - Do not expose to heavy shock or vibration
 - Do not use as a limit stop

Adjustment

- ▶ The safety switch may only be used with the corresponding actuator **PSEN 1,1-20**.
- ▶ Always test the function with the PSEN ix1 interface and one of the approved evaluation devices.
- ▶ The stated operating distances (see Technical details) only apply when the safety switch and actuator are installed facing each other in parallel. Switching distances may deviate if other arrangements are used. Note the maximum permitted lateral and vertical offset (see "Operating distances" and "Max. lateral and vertical offset").

PSENmag

PSEN 1.1p-25

NOTICE

This data sheet is only intended for use during configuration. For installation and operation, please refer to the operating instructions supplied with the unit.

Dimensions

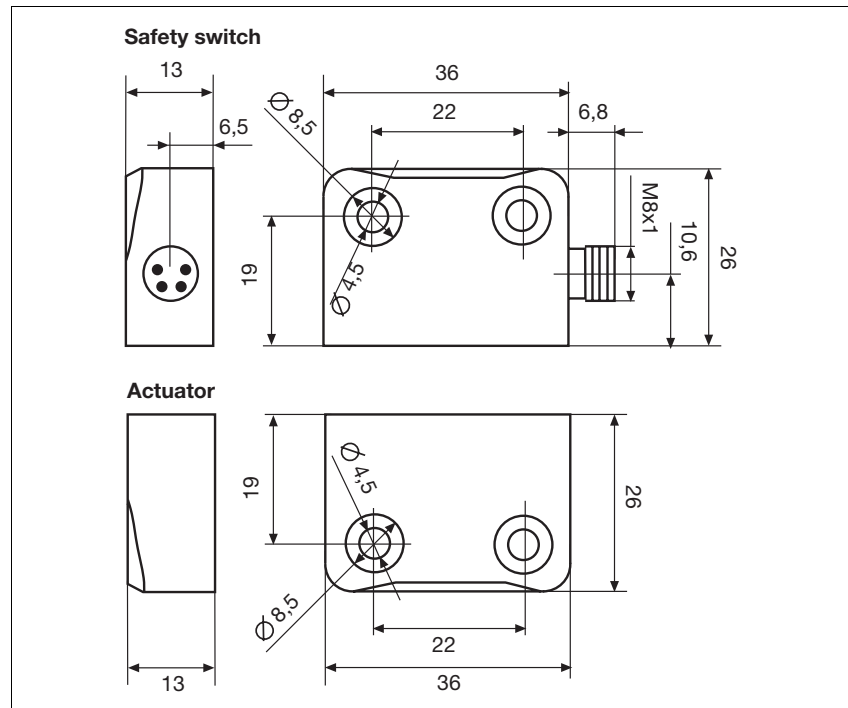

Technical details

ATEX category	II 3GD EEx nC IIC T6
Switching distances	
Assured operating distance S_{ao}	8 mm
Min. operating distance S_{omin}	0.5 mm
Assured release distance S_{ar}	26 mm
Switching voltage	24 V
Max. switching current for reed contacts	0.50 A
Max. breaking capacity for reed contacts	10.0 W
Max. switch frequency	1 Hz
Actuator	PSEN 1,1-20
Ambient temperature	-10 - 55 °C
Vibration to EN 60947-5-2	
Frequency	10 - 55 Hz
Amplitude	1.00 mm
Shock stress	30 g , 11 ms
Connection type	M8
Cable	LiYY 4 x 0,25 mm²
Protection type	IP65, IP67
Housing material	PBT

PSENmag

PSEN 1.1p-25

Technical details

Dimensions	
Safety switch	
Height	42.8 mm
Width	26.0 mm
Depth	13.0 mm
Actuator	
Height	36 mm
Width	26 mm
Depth	13 mm
Weight	
Safety switch	14 g
Actuator	17 g

The standards current on **2006-12** apply.

Order reference

Type	Quantity	Operation	Features	Order no.
PSEN 1.1p-25	1/1	magnetic	Safety switch/actuator	504 225
PSEN 1.1-20	1	magnetic	Actuator	514 120